

# The aesthetic synthesis of comfort and security.

Hawa Junior 100  
for glass applications

Barrier-free  
sliding doors  
from glass

# Hawa Junior 100 for glass applications

## Everything for more openness and transparency

New

Transparent yet insulating. Light and airy effect, but dimensionally stable and resistant to heat and dirt. Used for millennia, yet state-of-the-art: the versatility of glass has fascinated architects for as long as their profession has existed. And with the current need for energy efficiency and open, light rooms, glass has regained relevance in recent times

The Hawa Junior 100 provides the best arguments for upgrading the design of interior rooms with glass structures. It now effortlessly moves doors weighing up to 100 kg, and gives even more freedom to your design ideas with this increase in weight and dimensions. In so doing, it elevates sliding doors to a new level of comfort with its magnetic soft closing system and sliding characteristics which are the best in its class.

And the invisibly integrated technology supports filigree constructions which complement the transparency of the material.



Open, bright rooms and yet the necessary privacy –  
For example, for home office work.



**Comfort due to new soft and self closing system for lowest opening force**

The Hawa Junior 100 also owes its incomparable comfort to the SoftMove 100 magnetic soft closing system. Opening forces with a maximum of 22 N set new standards in this area.

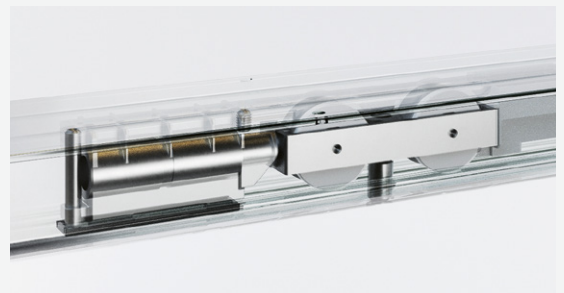

**Unique performance guarantee:  
Joy that lasts. For a long time.**

For the Hawa Junior 100 with a soft closing system, Hawa Sliding Solutions offers a 15-year performance guarantee for private use, and 7 years for commercial use, with incomparably low opening forces of a maximum of 22 N.

<b>15</b> years	<b>Performance guarantee</b> private use
<b>7</b> years	<b>Performance guarantee</b> commercial use



# More inclusion, fewer barriers

## Sliding doors are now also fully accessible



Doors often present a major obstacle for people with physical disabilities. But well planned sliding doors can offer benefits that swing doors cannot.

---

More inclusion, fewer barriers: This global trend is also being reflected in modern architectural concepts to an ever-increasing degree. And with the new Hawa Junior 100 GP and GP Pocket, for the first time glass sliding solutions are available which even fulfil the criteria for fully accessible opening in conjunction with an innovative magnetic soft closing system and high-quality rollers.

This makes it possible to move doors weighing up to 100 kg with minimal force of just 22 N. Particularly in view of diminishing strength in the later stages of life or for people with physical limitations, this is a valuable everyday aid, particularly since the unique Hawa performance guarantee also provides long-term planning security.

**The earlier this experiences are channeled into the development and construction process, the more inclusivity and foresight can go into the design of buildings and spaces.**

# Benefits at a glance

## Comfort, reliability, and aesthetics at the highest level

### Hawa Junior 100 for glass applications in brief



#### Comfort

Magnetic soft closing system with barrier-free opening forces of max. 22 N.

Quiet running thanks to rollers made of high-performance plastic and precision ball bearings.

Doors are silently braked and pulled closed.



#### Security

Tested for 100,000 cycles and maintenance-free for the entire service life.

Unique performance guarantee: 15 years for private use and 7 years for commercial use on low opening forces of max. 22 N.

Barrier-free according to DIN 18040-2 / 25 N.



#### Productivity

Simple height adjustment on fully installed door.

High degree of pre-assembly and simple storage.



#### Flexibility

New weight class: now for glass doors up to 100 kg.

Glass thicknesses from 8 to 12.7 mm for ESG (tempered safety glass) and VSG (float glass).

Laminated glass made from tempered safety glass.



#### Aesthetics

Expanded space concepts thanks to the discreetness of the door in the wall pocket

Simple, reduced design with technology that is invisibly integrated in the running track.

Clip-on panels in various design versions.

### Technical product information

You will find all of the necessary ordering information for the Hawa Junior 100 for applications on the following pages.

Hawa Junior 100 GP



see page 6

Hawa Junior 100 GP Pocket





see page 14

**Fitting for top-running glass doors up to 100 kg (220 lbs.), with running track flush with the ceiling. Optionally with soft and self closing mechanism. Wall or ceiling mounting. Minimal installation height.**

**Product highlights**

-  **Comfort** Accessible opening and soft and self closing at both sides from door widths of 800 mm (2' 7 1/2")
-  **Flexibility** Running tracks for wall and ceiling mounting with integrated clip-on system
-  **Security** Performance guarantee: 15 years for private use and 7 years for commercial use on incomparably low opening forces of max. 22 N

**Technical specifications**

-  Max. 100 kg (220 lbs.)
-  Max. 4000 mm (13' 1 15/32")
-  Max. 3000 mm (9' 10 1/8")
-  8-12.7 mm (5/16" to 1/2")

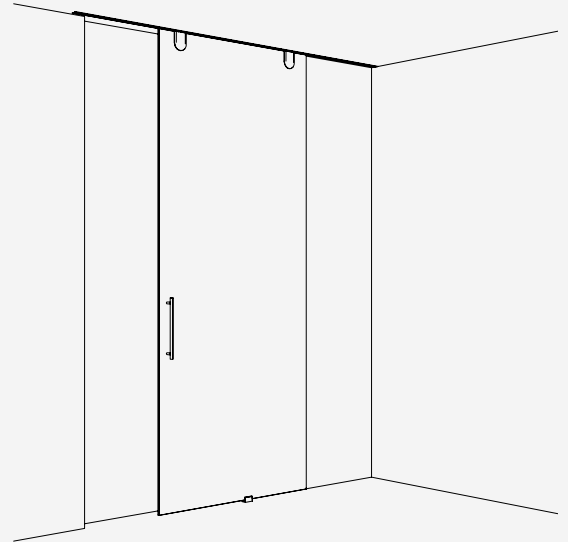

**Installation examples**

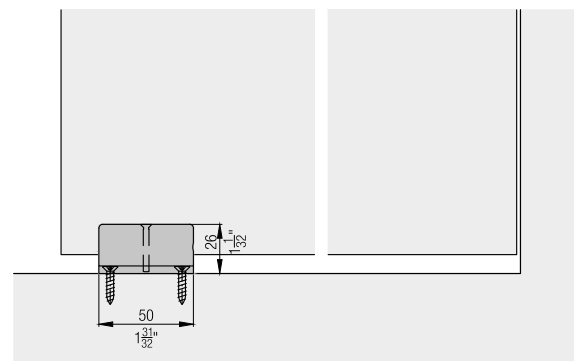
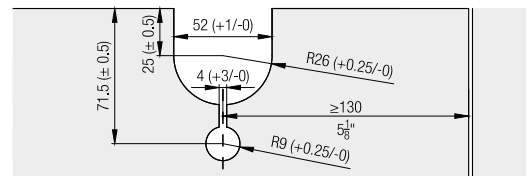
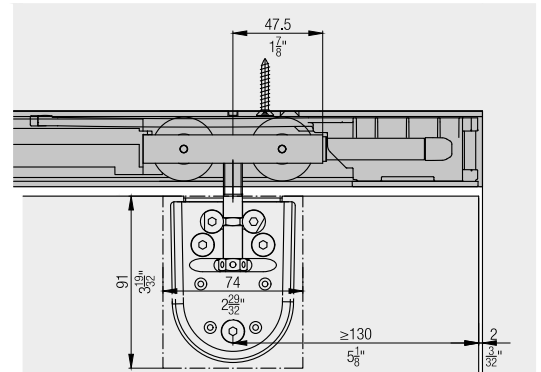
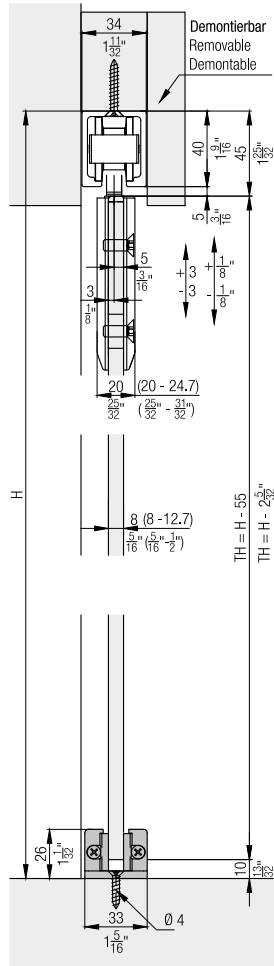
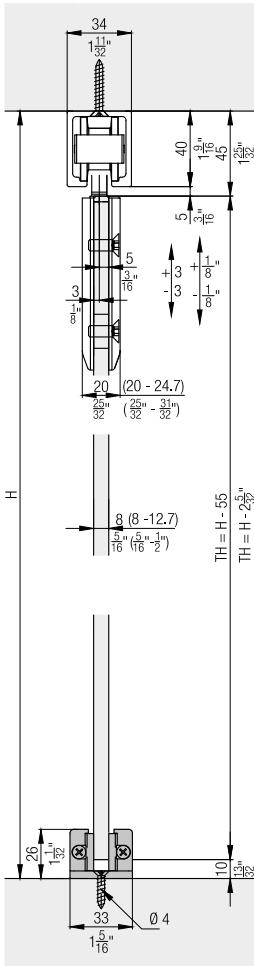









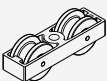
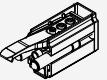



**Set for 1 glass door up to 100 kg (220 lbs.)**

	No.
Hawa Junior 100 GP, for 1 door	30720
Hawa Junior 100 GP, for 1 door, with 1 soft closing mechanism SoftMove 100	30764
Hawa Junior 100 GP, for 1 door, with 2 soft closing mechanisms SoftMove 100	30765













**Set consisting of:**

		30720	30764	30765	No.
	Running gear, 2-wheeled, M10, ball bearing	2	1		30137
	SoftStop Hawa Junior 80/100, with adjustable retention spring	2	1		27771
	Suspension bolt M10 and mounting screws	2	2	2	16018
	Patch suspension, with glass holder insert, without mounting screws	2	2	2	20505
	Screw-on rubber door stop	1	1	1	10629
	Single use drilling jig	1	1	1	20400
	Vertical adjustment pin	1	1	1	16329
	Soft close SoftMove 100, with running gear, stopper and cover, premounted		1	2	30509

**Bottom guides**

		No.
	Bottom guide, playfree adjustable, glass thickness 8–12.7 mm (5/16" to 1/2"), chrome-plated, mat	057.3082.071
	Sliders, for 10 mm glass (13/32"), self-adhesive, 6-piece set	16193
	Sliders, for 8 mm (5/16") glass, self-adhesive, 6-piece set	16192

**Cover caps**

		No.
	Cover cap, rounded, plastic, chrome-plated, matt, 1 piece	16049
	Cover cap, rounded, plastic, chrome-plated, matt, 4-piece set	16042
	Cover cap, rounded, plastic, chromium finish polished, 1 piece	17161
	Cover cap, rounded, plastic, chromium finish polished, 4-piece set	17160
	Cover cap, rounded, plastic, stainless steel look, 1 piece	16051
	Cover cap, rounded, plastic, stainless steel look, 4-piece set	16044
	Cover cap, rounded, plastic, raw, 1 piece	15823
	Cover cap, square, plastic, chrome-plated, matt, 1 piece	19091
	Cover cap, square, plastic, chrome-plated, matt, 4-piece set	19092
	Cover cap, square, plastic, stainless steel look, 1 piece	19093
	Cover cap, square, plastic, stainless steel look, 4-piece set	19094
	Square cover plate, plastic, raw, 1 piece	19000
	Cover cap to running track, both sides, steel, chrome-plated, matt	24956
	Cover cap to running track, both sides, steel, stainless steel look	24957



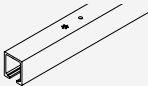

**Running tracks**

		mm (inch)	No.
	Running track, aluminum, anodized, pre-drilled	1,400 (4' 7 1/8 ")	10189
		1,600 (5' 3 ")	10190
		1,800 (5' 10 7/8 ")	10191
		2,000 (6' 6 3/4 ")	10192
		2,200 (7' 2 5/8 ")	10193
		2,500 (8' 2 7/16 ")	10194
		3,000 (9' 10 1/8 ")	18532
		4,000 (13' 1 15/32 ")	18533
		6,000 (19' 8 7/32 ")	10186
		cut to size	10188
	Running track, aluminum, stainless steel look, brushed, pre-drilled	2,500 (8' 2 7/16 ")	22048
		4,000 (13' 1 15/32 ")	20005
		6,000 (19' 8 7/32 ")	20004
		cut to size	20006

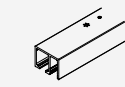

**Guide tracks**

		mm (inch)	No.
	Guide track, aluminum, anodized, pre-drilled	6,000 (19' 8 7/32 ")	14414
		cut to size	14415

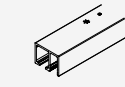

**Running track set with fixed glazing,  
2500 mm (8' 2 7/16"), aluminum, anodized**

		No.
Set running tracks, with fixed glass, aluminum, anodized, pre-drilled		20226
		No.
<b>Set consisting of:</b>		20226
	Running track, with fixed glass, aluminum, anodized, pre-drilled	1 20104
	Cover profile to running track with fixed glass, aluminum, anodized	1 19552

**Running track set with fixed glazing,  
4000 mm (13' 1 7/16"), aluminum, anodized**

		No.
Set running tracks, with fixed glass, aluminum, anodized, pre-drilled		20227
		No.
<b>Set consisting of:</b>		20227
	Running track, with fixed glass, aluminum, anodized, pre-drilled	1 20105
	Cover profile to running track with fixed glass, aluminum, anodized	1 19553

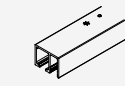

**Running track set with fixed glazing,  
6000 mm (19' 8 7/32"), aluminum, anodized**

		No.
Set running tracks, with fixed glass, aluminum, anodized, pre-drilled		20228
		No.
<b>Set consisting of:</b>		20228
	Running track, with fixed glass, aluminum, anodized, pre-drilled	1 20106
	Cover profile to running track with fixed glass, aluminum, anodized	1 19562

**Running track set with fixed glazing,  
2500 mm (8' 2 7/16"), aluminum, stainless steel effect**

		No.
Running track set, with fixed glass, aluminum, stainless steel look, brushed, pre-drilled		21270

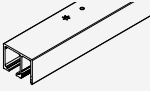
		21270	No.
<b>Set consisting of:</b>			

	Running track, with fixed glass, aluminum, stainless steel look, brushed, pre-drilled	1	21276
	Cover profile to running track, with fixed glass, stainless steel effect, brushed	1	21280

**Running track set with fixed glazing,  
4000 mm (13' 1 7/16"), aluminum, stainless steel effect**

		No.
Running track set, with fixed glass, aluminum, stainless steel look, brushed, pre-drilled		21271

		21271	No.
<b>Set consisting of:</b>			

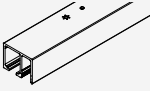
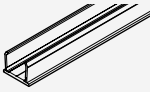
	Running track, with fixed glass, aluminum, stainless steel look, brushed, pre-drilled	1	21277
	Cover profile to running track, with fixed glass, stainless steel effect, brushed	1	21281

**Running track set with fixed glazing,  
6000 mm (19' 8 7/32"), aluminum, stainless steel effect**

		No.
Running track set, with fixed glass, aluminum, stainless steel look, brushed, pre-drilled		21272

		21272	No.
<b>Set consisting of:</b>			

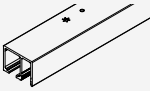
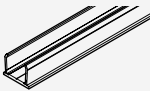
	Running track, with fixed glass, aluminum, stainless steel look, brushed, pre-drilled	1	21278
	Cover profile to running track, with fixed glass, stainless steel effect, brushed	1	21282

**Soft close SoftMove 100**



For soft closing in opening and closing direction order 2 sets.

		No.
	Soft close SoftMove 100, with running gear, stopper and cover, premounted	30509

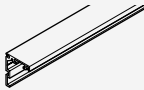
**Angled profiles for wall mounting**



		mm (inch)	No.
	Angled profile for wall mounting, aluminum, anodized, pre-drilled	2,500 (8' 2 7/16")	24953
		4,000 (13' 1 15/32")	24952
		6,000 (19' 8 7/32")	24951
		cut to size	24954

**Individual components to angled profile**

		No.
	Assembly set to angled profile, 10-piece set	17786
	Cover cap to angled profile, steel, chrome-plated, matt, suitable to both side	24961
	Connecting pins to profiles, 2-piece set	21347

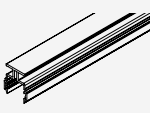
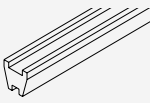
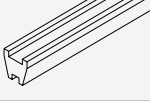

**Hawa Adapto 80 concrete casting system,  
without fixed glazing**

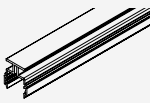
	No.
Inset profile for concrete surfaces Hawa Adapto 80, without fixed glass, 2500 mm (8' 2 7/16")	20216
Inset profile for concrete surfaces Hawa Adapto 80, without fixed glass, 4000 mm (13' 1 15/32")	20217

Set consisting of:		mm (inch)	20216	20217	No.
	Inset profile for concrete surfaces, without fixed glass, aluminum	2,500 (8' 2 7/16")	1		20087
	Polystyrene insert, without fixed glass	1,000 (3' 3 3/8 ")	2	4	19418
	Polystyrene insert, without fixed glass	500 (1' 7 11/16")	1		19556
	Assembly clips, plastic, black, without fixed glass		4	5	19344
	Cover cap, without fixed glass, plastic, gray		2	2	19366
	Inset profile for concrete surfaces, without fixed glass, aluminum	4,000 (13' 1 15/32")		1	20088

**Hawa Adapto 80 concrete casting system,  
with fixed glazing**

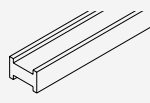
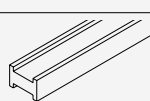
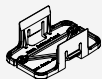

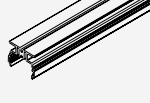

	No.
Inset profile for concrete surfaces Hawa Adapto 80, with fixed glass, 2500 mm (8' 2 7/16")	20220
Inset profile for concrete surfaces Hawa Adapto 80, with fixed glass, 4000 mm (13' 1 15/32")	20221

Set consisting of:		mm (inch)	20220	20221	No.
	Inset profile for concrete surfaces, with fixed glass, aluminum	2,500 (8' 2 7/16")	1		20094
	Polystyrene insert, 1000 mm (3' 3 1/4"), with fixed glass	1,000 (3' 3 3/8 ")	2	4	19555
	Polystyrene insert, with fixed glass	500 (1' 7 11/16")	1		19557
	Assembly clips, plastic black, with fixed glass		4	5	19568
	Cover cap, fixed glass, plastic, gray		2	2	19968
	Inset profile for concrete surfaces, with fixed glass, aluminum	4,000 (13' 1 15/32")		1	20095



**Assembly set for Hawa Adapto 80**

	No.
Assembly set, with countersunk head screw, length up to 2500 mm (8' 2 7/16")(8' 2 7/16")	22841
Assembly set, with countersunk head screw, length 2501–4000 mm (8' 2 15/32" to 13' 1 15/32")	22842

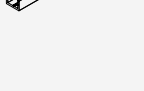

**Set consisting of:**

		22841	22842	No.
	Distance plate, plastic, 1 mm (1/32")	2	2	19398
	Distance plate, plastic, 2 mm (3/32")	2	2	19399
	Distance plate, plastic, 3 mm (1/8")	2	2	19400
	Distance plate, plastic, 5 mm (3/16")	4	4	19401
	Special countersunk screws, 6x21 mm (1/4"x13/16"), 10-piece set	1	2	22844

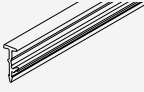
**Base/wall profiles and rubber profiles for fixed glazing**

		mm (inch)	No.
	Bottom-/wall profile to fixed glass, aluminum, anodized, pre-drilled	2,500 (8' 2 7/16")	19549
		6,000 (19' 8 7/32")	19561
		cut to size	20067
	Bottom-/wall profile to fixed glass, aluminum, stainless steel look, brushed, pre-drilled	4,000 (13' 1 15/32")	21285
		6,000 (19' 8 7/32")	21286
		cut to size	21287
	Rubber profile, black, to fixed glass 8–9.9 mm (5/16" to 13/32")	10,000 (32' 9 11/16")	25787
		10,000 (32' 9 11/16")	25789
	Rubber profile, black, to fixed glass 10–12 mm (13/32" to 15/32")	10,000 (32' 9 11/16")	25789
	Rubber profile, black, to fixed glass 12.1–13.1 mm (15/32" to 1/2")	10,000 (32' 9 11/16")	25763





**Wall connection**

		mm (inch)	No.
	Wall profile, aluminum, anodized	2,500 (8' 2 7/16")	17020
		3,500 (11' 5 25/32")	17021
	Wall profile, aluminum, stainless steel look, brushed	2,500 (8' 2 7/16")	20119
		3,500 (11' 5 25/32")	20120
	Seal profile, black, for wall profile	2,500 (8' 2 7/16")	16452
		3,500 (11' 5 25/32")	16453

**Protective edge trims**

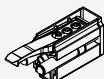
		mm (inch)	No.
	Rubber profile self-adhesive, black, for 8–12.7 mm (5/16" to 1/2") glass thickness, glass distance 4 mm (5/32")	5,000 (16' 4 27/32")	19442
		10,000 (32' 9 11/16")	19443
		50,000 (164' 1/2")	19444
	Rubber profile self-adhesive, translucent, for 8–12.7 mm (5/16" to 1/2") glass thickness, glass distance 4 mm (5/32")	5,000 (164' 27/32")	19445
		10,000 (32' 9 11/16")	19446
		50,000 (164' 1/2")	19447

**Accessories**



		No.
	SoftStop Hawa Junior 80/100, with adjustable retention spring	27771
	Bottom door stopper, with centering, stainless steel look	21473
	Bottom door stopper, with centering, chrome-plated, matt	20773
	Centering assembly grey, for all glass sliding doors	18619
	Centering assembly black, for all glass sliding doors, to wall profile	18663









**Fitting for top-running glass doors up to 100 kg (220 lbs.), with surface mounted running track or running track flush with the ceiling. Optionally with soft and self closing mechanism. Ceiling mounting. Minimal installation height. Wall pocket solution.**

**Product highlights**

-  **Comfort** Accessible opening and soft and self closing at both sides from door widths of 800 mm (2' 7 1/2")
-  **Productivity** Door can be installed in pocket after construction is complete
-  **Security** Performance guarantee: 15 years for private use and 7 years for commercial use on incomparably low opening forces of max. 22 N

**Technical specifications**

-  Max. 100 kg (220 lbs.)
-  Max. 4000 mm (13' 1 15/32")
-  Max. 1500 mm (4' 11 1/16")
-  8–12.7 mm (5/16" to 1/2")

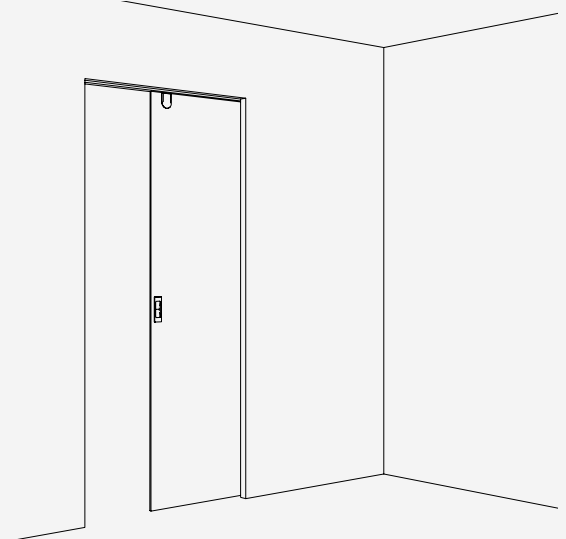



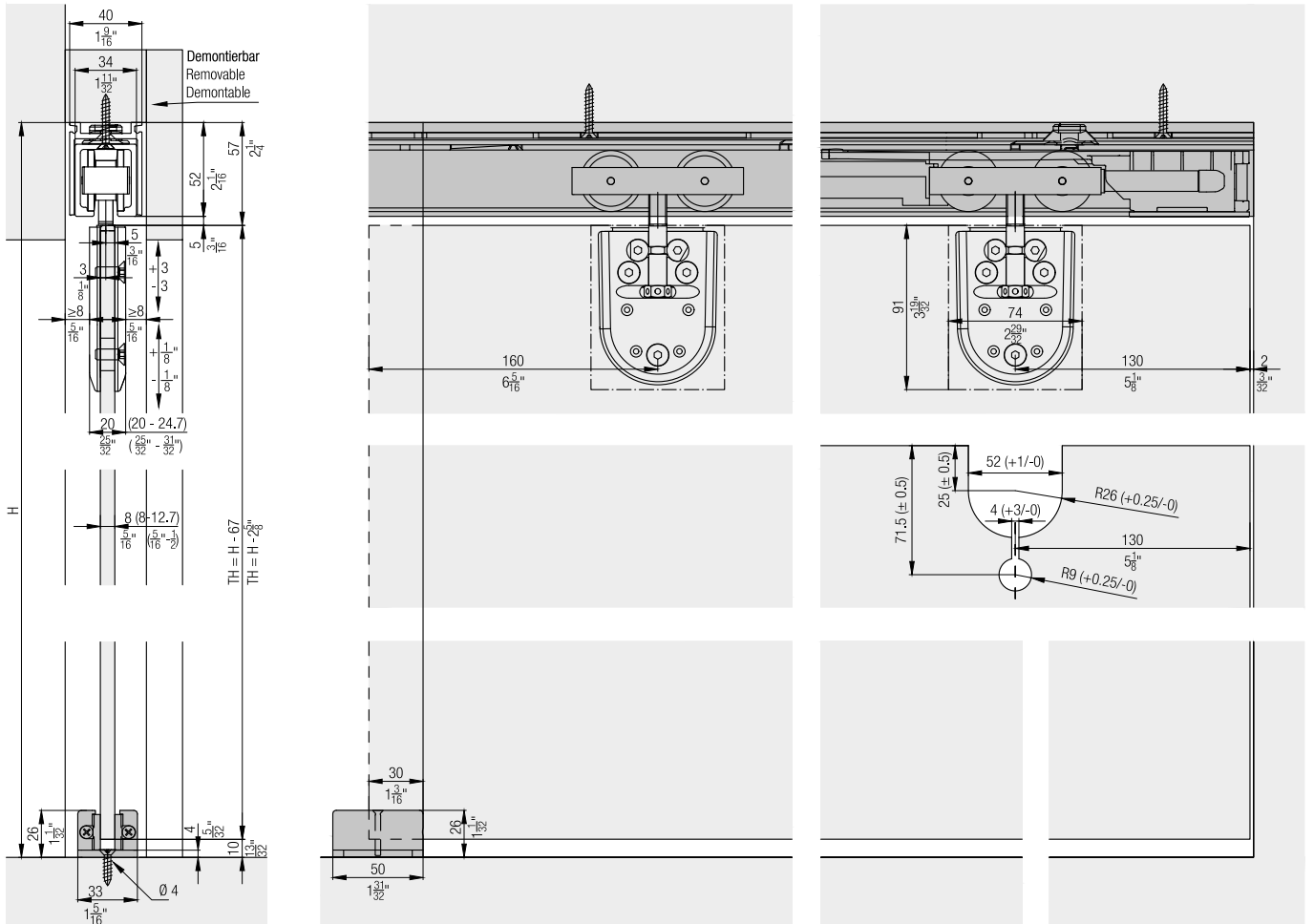

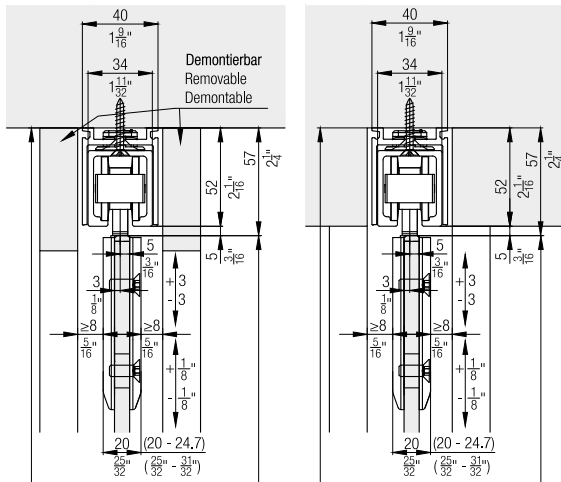

**Installation examples**

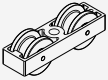
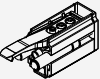

Further installation examples















**Set for 1 glass door up to 100 kg (220 lbs.)**

		No.	
Hawa Junior 100 GP, for 1 door		30720	
		30720	No.
<b>Set consisting of:</b>			
	Running gear, 2-wheeled, M10, ball bearing	2	30137
	SoftStop Hawa Junior 80/100, with adjustable retention spring	2	27771
	Suspension bolt M10 and mounting screws	2	16018
	Patch suspension, with glass holder insert, without mounting screws	2	20505
	Screw-on rubber door stop	1	10629
	Single use drilling jig	1	20400
	Vertical adjustment pin	1	16329

**Bottom guides**

		No.
	Bottom guide, playfree adjustable, glass thickness 8–12.7 mm (5/16" to 1/2"), chrome-plated, mat	057.3082.071

**Cover caps**

		No.
	Cover cap, rounded, plastic, chrome-plated, matt, 1 piece	16049
	Cover cap, rounded, plastic, chrome-plated, matt, 4-piece set	16042
	Cover cap, rounded, plastic, chromium finish polished, 1 piece	17161
	Cover cap, rounded, plastic, chromium finish polished, 4-piece set	17160
	Cover cap, rounded, plastic, stainless steel look, 1 piece	16051
	Cover cap, rounded, plastic, stainless steel look, 4-piece set	16044
	Cover cap, rounded, plastic, raw, 1 piece	15823
	Cover cap, square, plastic, chrome-plated, matt, 1 piece	19091
	Cover cap, square, plastic, chrome-plated, matt, 4-piece set	19092
	Cover cap, square, plastic, stainless steel look, 1 piece	19093
	Cover cap, square, plastic, stainless steel look, 4-piece set	19094
	Square cover plate, plastic, raw, 1 piece	19000

**Running tracks**

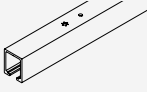

		mm (inch)	No.
 Running track, aluminum, anodized, pre-drilled		1,400 (4' 7 1/8 ")	10189
		1,600 (5' 3 ")	10190
		1,800 (5' 10 7/8 ")	10191
		2,000 (6' 6 3/4 ")	10192
		2,200 (7' 2 5/8 ")	10193
		2,500 (8' 2 7/16 ")	10194
		3,000 (9' 10 1/8 ")	18532
		cut to size	10188

**Assembly set, up to 2000 mm (6' 6 3/4")**

		No.
Set for mountable and demountable running track		25207

		mm (inch)	No.	
		2,035 (6' 8 1/8 ")	1	25212
		2,520	1	25520

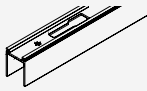
**Set consisting of:**



 Retainer profile with a bayonet lock, aluminum, anodized		2,035 (6' 8 1/8 ")	1	25212
 Small parts to retainer profile, 6-piece set			1	25520

**Assembly set, up to 2500 mm (8' 2 7/16")**

		No.
Set for mountable and demountable running track		25371

		mm (inch)	No.	
		2,535 (8' 3 13/16 ")	1	25443
		25371	1	25521

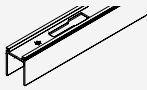
**Set consisting of:**



 Retainer profile with a bayonet lock, aluminum, anodized		2,535 (8' 3 13/16 ")	1	25443
 Small parts to retainer profile, 7-piece set			1	25521

**Assembly set, up to 3000 mm (9' 10 1/8")**

		No.
Set for mountable and demountable running track		25441

		mm (inch)	No.	
		3,035 (9' 11 1/2 ")	1	25444
		25441	1	25522

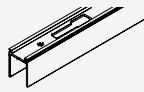
**Set consisting of:**

 Retainer profile with a bayonet lock, aluminum, anodized		3,035 (9' 11 1/2 ")	1	25444
 Small parts to retainer profile, 9-piece set			1	25522

**Panels**



		mm (inch)	No.
 Clip-on panel, for fascia mounting, aluminum, anodized		2,000 (6' 6 3/4 ")	25445
		cut to size	27693

**Soft close SoftMove 100**



For soft closing in opening and closing direction order 2 sets.

		No.
 Soft close SoftMove 100, with running gear, stopper and cover, premounted		30509

**Wall connection**

		mm (inch)	No.
 Wall profile, aluminum, anodized		2,500 (8' 2 7/16 ")	17020
		3,500 (11' 5 25/32 ")	17021
 Wall profile, aluminum, stainless steel look, brushed		2,500 (8' 2 7/16 ")	20119
		3,500 (11' 5 25/32 ")	20120
 Seal profile, black, for wall profile		2,500 (8' 2 7/16 ")	16452
		3,500 (11' 5 25/32 ")	16453

**Accessories**

		No.
	Spring loaded stopper Hawa Junior 80/100	25370
	Centering assembly grey, for all glass sliding doors	18619
	Centering assembly black, for all glass sliding doors, to wall profile	18663

**Calculations of running track length**

The length of the running track must be shorter than the diagonal clearance (P2) by at least 80 mm (3 5/32").

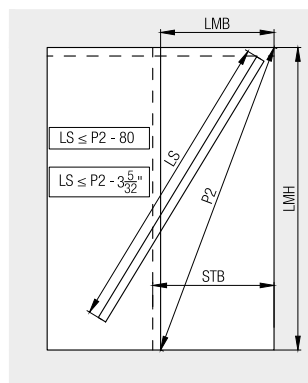

LMB = inside clearance  
LMH = inside height  
STB = sliding door width  
P2 = diagonal clearance  
LS = running track

**Spring stop**

The specially developed spring stop for ejecting the door is integrated into the running track without visible fittings on the door edge.

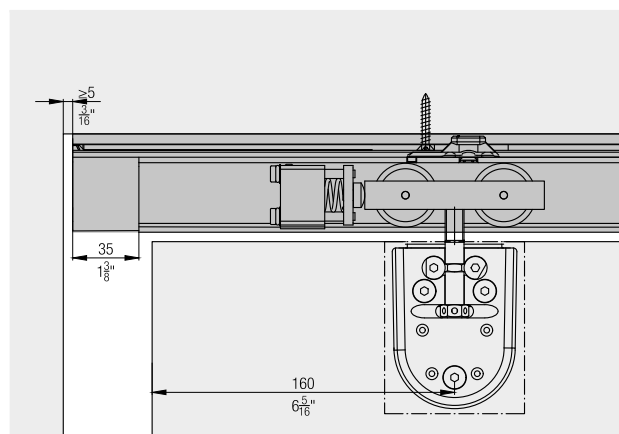



**Detail rear door**

Installation circumstances for bottom guide, rear suspension.

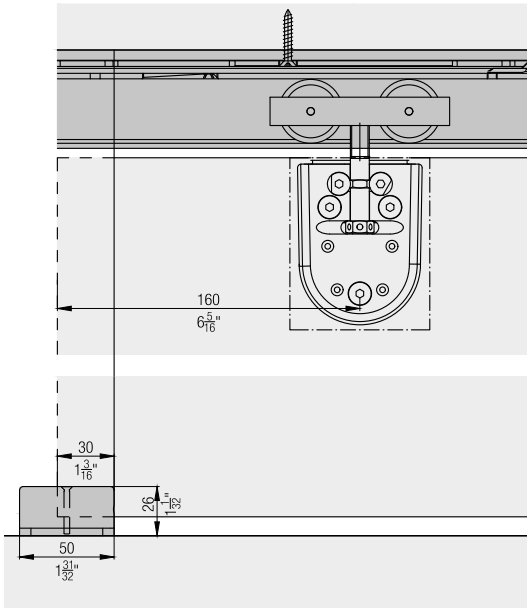

**Wall connection**

Optimal wall connection for all-glass sliding doors with unprotected glass edge.

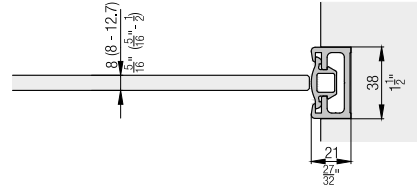

**Facing for the retainer profile**

The optional clip-on panel made of aluminum can be clipped onto the retainer profile without additional fixing components. For invisible fastening of the lintel panelling, there is the option of covering the clip panel on site, using panels up to 40 mm (1 9/16 inches) thick.

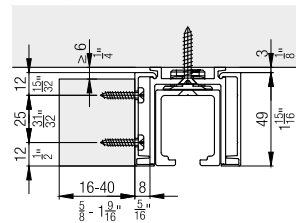

**SoftMove 100 magnetic soft closing mechanism**

Completely integrated into the running track, the SoftMove decelerates sliding doors and draws them into their final position.

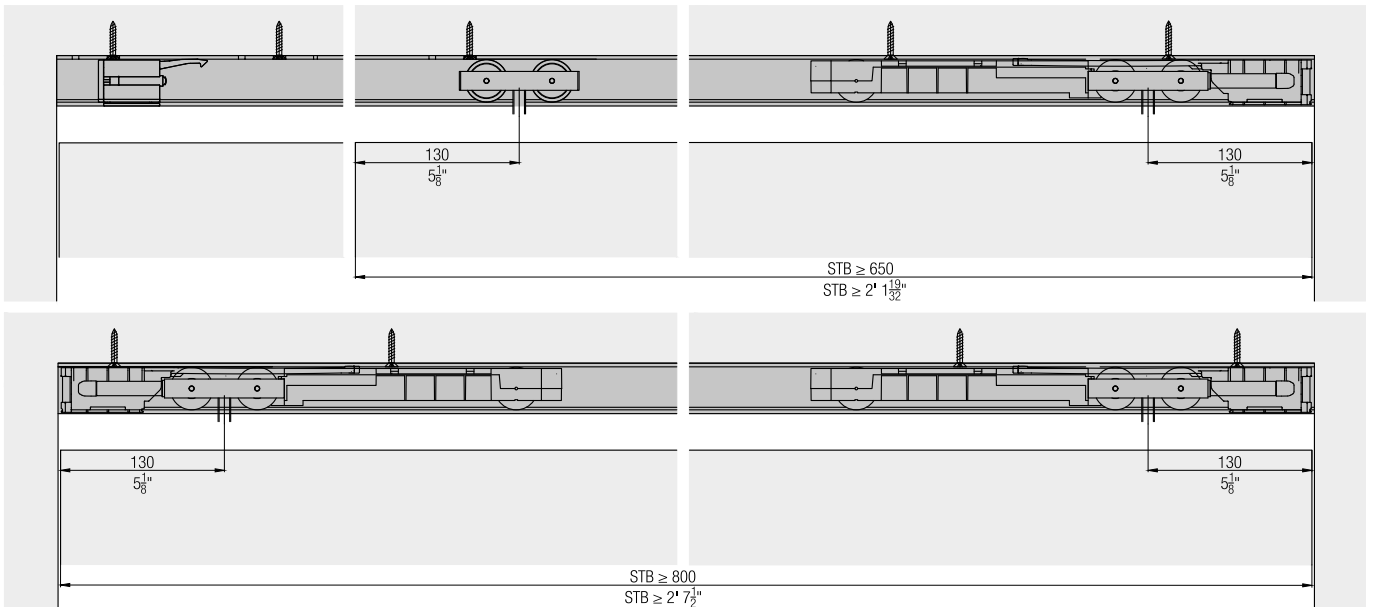

# Visit us online

---

At [www.hawa.com/junior-glass](http://www.hawa.com/junior-glass) you will find all the relevant details about this high-quality fitting solution by Hawa Sliding Solutions. See for yourself: The new Hawa Junior 100 will win your customers over almost as easily as it moves glass doors.

We would be happy to advise you personally. Contact us at [info@hawa.com](mailto:info@hawa.com) or by phone under +41 44 787 17 17.